

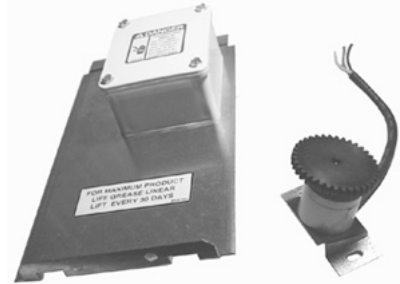

Potentiometer Assembly Installation & Operator's Instruction Manual

Thank You

The employees of Agile Manufacturing would like to thank you for your recent ProTerra® purchase. If a problem should arise, your ProTerra® distributor can supply the necessary information to help you.



General

The ProTerra® Potentiometer Assembly is used to Control travel of the ProTerra® Winch. Using this equipment for any other purpose or in a way not within the operating recommendations specified in this manual will void the warranty and may cause personal injury.

This manual is designed to provide comprehensive planning, installation, safety, operation, and parts listing information.

Safety Information

Carefully read all safety messages in this manual and on your equipment safety signs. Follow recommended precautions and safe operating practices. Keep safety signs in good condition. Replace missing or damaged safety signs.

DANGER: Electrical Hazard

Disconnect electrical power before inspecting or servicing equipment. Ground all electrical equipment for safety. All electrical wiring must be done by a qualified electrician in accordance with local and national electric codes. Ground all non-current carrying metal parts to guard against electrical shock. With the exception of motor overload protection, electrical disconnects and over current protection are not supplied with the equipment.



DANGER: Rotating Parts

Severe personal injury will result, if the electrical power is not disconnected, prior to servicing the equipment. Do Not operate with cover removed.

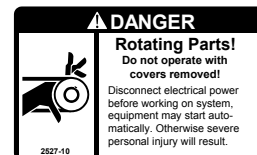

Potentiometer Installation

Run the Winch to move the Bronze Nut all the way to the motor end, with the outer and inner shut-off Set Collars together at the end of the operating range (See Figure 1). If the Winch has been connected to an inlet cable system, and is set to stop at the inner Set Collar somewhere else on the Switch Rod, disconnect the Winch from the Inlet system cable to allow the Set Collars to be located together. This will allow the Winch to be fully synchronized with the Potentiometer Assembly. Remove the four 1/4-20 Nuts (Item 3, Figure 1), and remove the existing Lower Cover Panel from the Winch Assembly. This part can be discarded. Remember how the Lower Cover Panel came off because the new Lower Cover Panel included with your Potentiometer Assembly will go back on the same way.

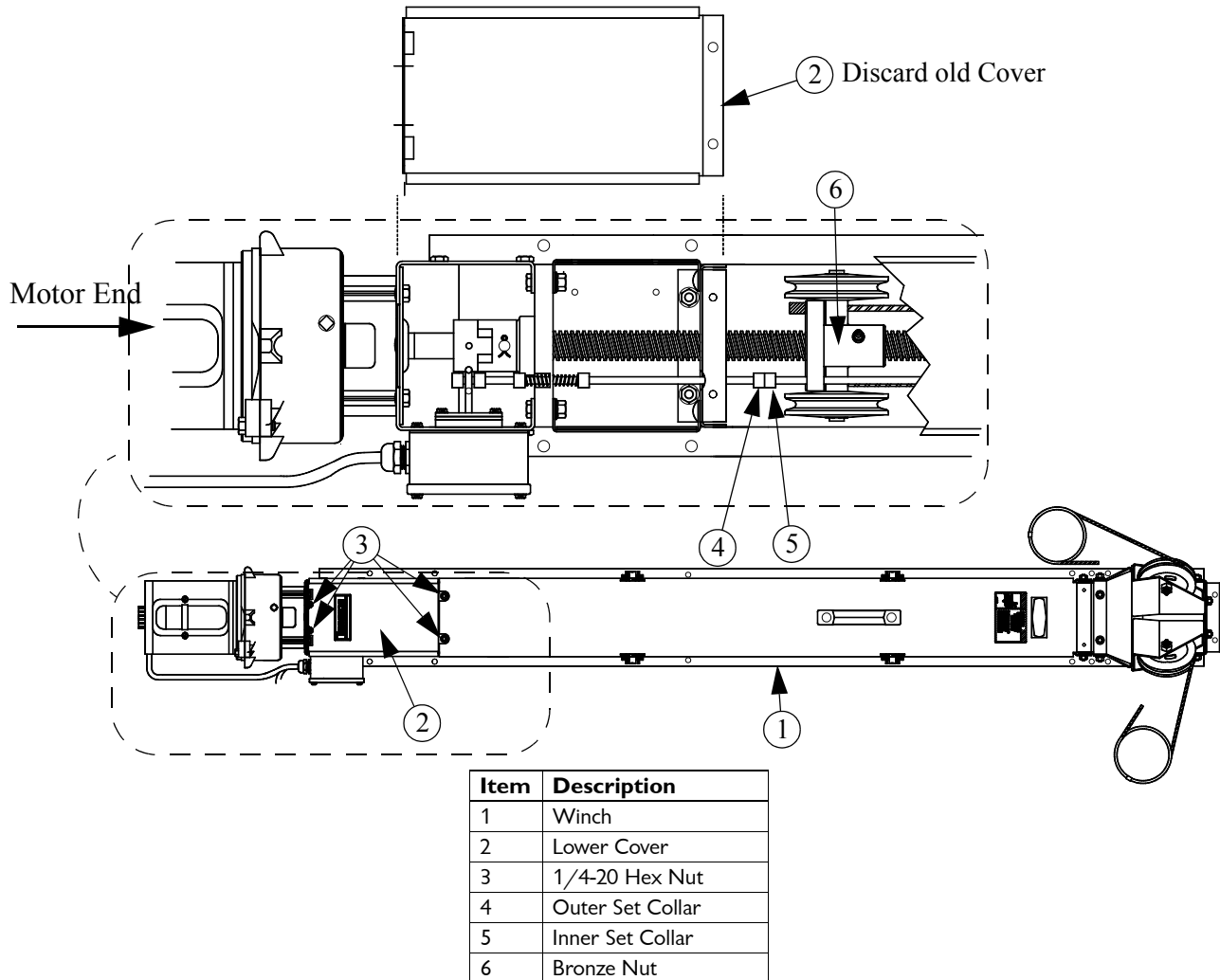
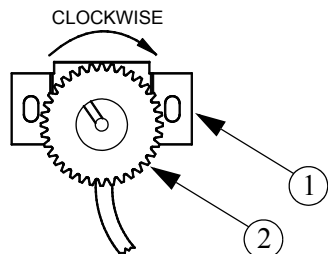

Figure 1. Removing the Cover and Collar Position

With the cord pointed down as shown below, wind the Potentiometer Assembly Gear **CLOCKWISE** until it stops (See Figure 2). Now turn the gear **COUNTER-CLOCKWISE** for half a turn. The Potentiometer Assembly is now set for the full stroke range of the Winch.



Item	Description
1	Potentiometer Assembly
2	Potentiometer Assembly Gear

Figure 2. Setting Potentiometer

Set the Potentiometer Assembly over the holes in the base, inside the Winch Housing (See Figure 3).

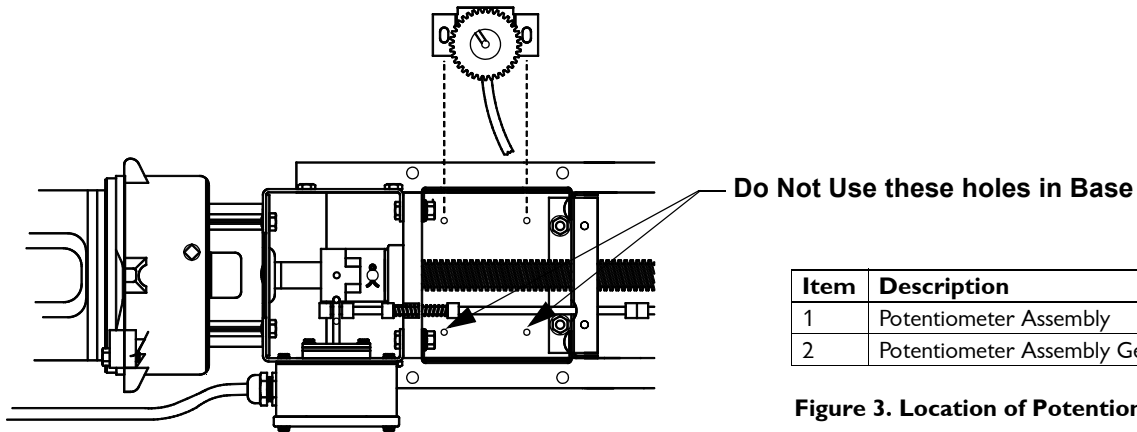

Item	Description
1	Potentiometer Assembly
2	Potentiometer Assembly Gear

Figure 3. Location of Potentiometer

Use the two screws taped to the new Cover Assembly to fasten the Potentiometer Assembly to the Base (See Figure 4). **Do not tighten.** Slide the Potentiometer Assembly toward the Threaded Drive Rod until the teeth of the Gear make full contact with the Drive Rod threads. Tighten the Screws in the Base. Route the cord under the threaded Drive Rod and the Switch Actuator Rod and on through the black fitting on the new Cover Assembly. Allow 2" to 3" cord through the fitting for easy wire connection inside the white plastic connection box. Tighten the black fitting to the cord and attach the new Cover Assembly to the Winch just as the old one was attached.

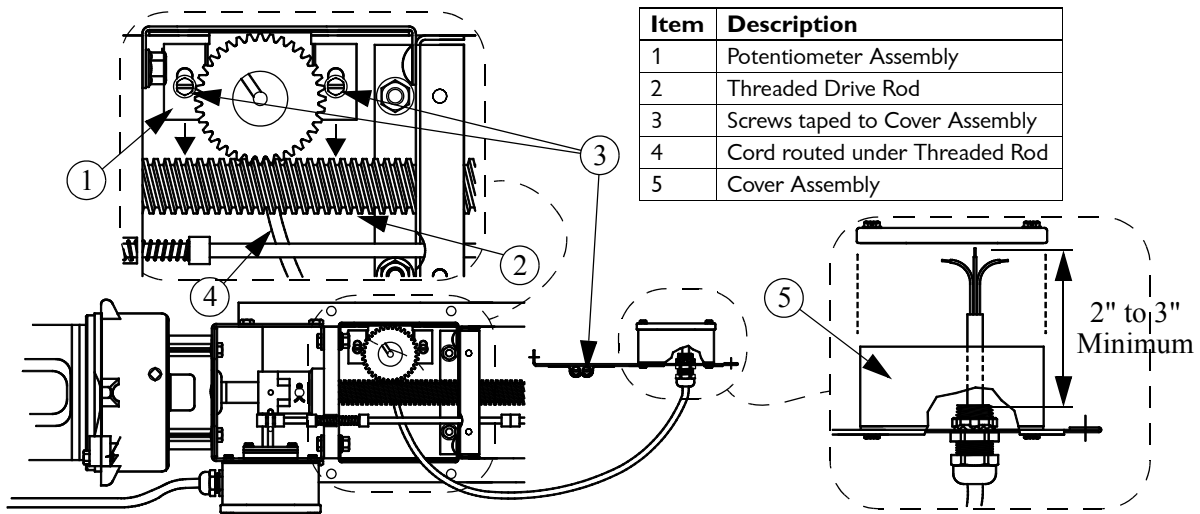

Item	Description
1	Potentiometer Assembly
2	Threaded Drive Rod
3	Screws taped to Cover Assembly
4	Cord routed under Threaded Rod
5	Cover Assembly

Figure 4. Positioning and Fastening Potentiometer Assembly

Parts List

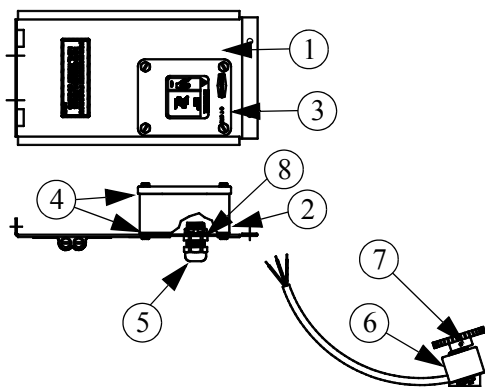

Item	Description	Part Number
1	Lower Linear Lift® Cover	47835-2
2	Terminal Box	36649
3	Switch Box Cover	6776
4	Gasket	6777
5	Liquid Tight Connector 1/2"	23779
6	Potentiometer Assembly	48182
7	Potentiometer Gear (16 Pitch 36 Tooth)	41825
8	Conduit Lock Nut with Seal	39-20512

Potentiometer Wiring and Mounting

The correct wiring of the Potentiometer leads for the Control signal depends on the mounting and application of the Winch. **Figure 5** shows how the unit can be used either to close the attachment by retracting cable into the unit or by extending cable out of the unit. The proper lead connections are shown in **Figure 5**.

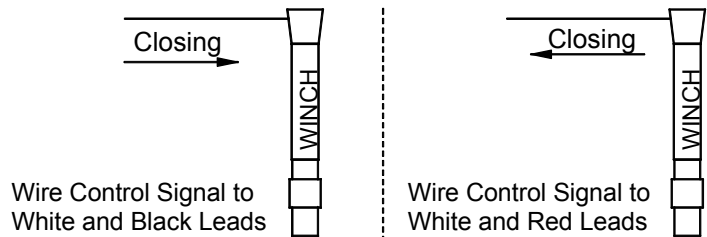

Figure 5. Potentiometer Wiring Leads

Potentiometer Connection and Operation

Figure 6 shows the schematic of the Potentiometer and which color lines are associated with rotation, direction, and position of the Bronze Nut.

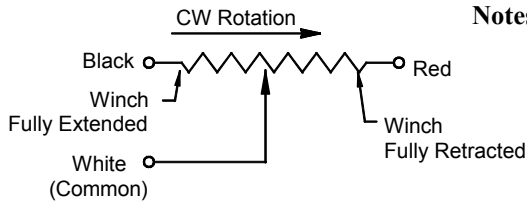

Figure 6. Connection and Operation

- Notes:**
- 1) Resistance across White & Red is maximum when fully extended.
 - 2) Resistance across White and Black is maximum when fully retracted.
 - 3) Potentiometer rotation is defined as the turning direction when viewed from the shaft side of the Potentiometer.
 - 4) Controllers read increasing resistance=curtain closing.
 - 5) Potentiometer is a 10-turn device that reads from 0 to 10 KOHM.

Warranty

Agile Manufacturing warrants each new ProTerra® product manufactured by it to be free from defects in material or workmanship for one year from and after the date of initial installation by or for the original purchaser. If such a defect is found by the Manufacturer to exist within the one-year period, the Manufacturer will, at its option, (a) repair or replace such product free of charge, F.O.B. the factory of manufacture, or (b) refund to the original purchaser the original purchase price, in lieu of such repair or replacement. Labor costs associated with the replacement or repair of the product are not covered by the Manufacturer.

Conditions and Limitations

1. The product must be installed by and operated in accordance with the instructions published by the **Manufacturer or Warranty will be void.**
2. Warranty is void if **all components** of the system are not original equipment supplied by the **Manufacturer.**
3. This product must be purchased from and installed by an authorized distributor or certified representative thereof or the Warranty will be void.
4. Malfunctions or failure resulting from misuse, abuse, negligence, alteration, accident, or lack of proper maintenance shall not be considered defects under the Warranty.
5. This Warranty applies only to systems for the care of poultry and livestock. Other applications in industry or commerce are not covered by this Warranty.

The **Manufacturer** shall not be liable for any **Consequential or Special Damage** which any purchaser may suffer or claim to suffer as a result of any defect in the product. **“Consequential” or “Special Damages”** as used herein include, but are not limited to, lost or damaged products or goods, costs of transportation, lost sales, lost orders, lost income, increased overhead, labor and incidental costs and operational inefficiencies.

THIS WARRANTY CONSTITUTES THE MANUFACTURER’S ENTIRE AND SOLE WARRANTY AND THIS MANUFACTURER EXPRESSLY DISCLAIMS ANY AND ALL OTHER WARRANTIES, INCLUDING, BUT NOT LIMITED TO, EXPRESS AND IMPLIED WARRANTIES AS TO MERCHANTABILITY, FITNESS FOR PARTICULAR PURPOSES SOLD AND DESCRIPTION OR QUALITY OF THE PRODUCT FURNISHED HEREUNDER.

ProTerra® Distributors are not authorized to modify or extend the terms and conditions of this Warranty in any manner or to offer or grant any other warranties for ProTerra® products in addition to those terms expressly stated above. An officer of CTB, Inc. must authorize any exceptions to this Warranty in writing. The Manufacturer reserves the right to change models and specifications at any time without notice or obligation to improve previous models.

Agile Manufacturing
720 Industrial Park Rd.
Anderson, Missouri 64831 U.S.A.
Phone: 1-800-704-7356 • Web Site: www.proterrasystems.com • E-Mail: agile@agilemfg.net
Agile Manufacturing is a division of CTB Inc. Milford, Indiana

Printed in the U.S.A