



Backup Control 48275



- The Intelligro® Backup Control contains relays that are prewired for use with backup thermostats. This provides a backup system for an electronically controlled livestock or poultry facility. These relays are sized to conduct the actual motor current in one line of the power to the fans being backed up. The backup control is wired such that when the first backup thermostat turns on, or the 24VDC of the electronic climate control is lost, a maximum of four independent 1 hp loads turn on. Also, when used in a tunnel ventilated barn, the tunnel curtain is given an unconditional open signal while the close signal from the electronic climate control is blocked. A second thermostat turns on a maximum of an additional four independent 1 hp loads. Alternatively, it can be connected such that one thermostat turns on a maximum of eight independent 1 hp loads. (See **wiring diagram on following page**)
- The heater backup thermostat allows backing up two independent heat zones.
- As with all backup systems that depend on mechanical thermostats, it is essential that the temperature settings of the thermostats be adjusted close enough to the set temperature to protect the livestock or poultry. Every time the set temperature of the electronic climate control is changed, the backup thermostats must be readjusted appropriately.



! Danger !

Relays 1-7 have 230VAC 50/60 Hz. coils. Relay 8 has a 24VDC coil. The outputs of this backup box are meant to be connected directly to the output terminals of the control being backed up.

USE CAUTION NOT TO CROSS PHASES. It is assumed the other leg of the power to the motors goes directly to the motors.

Wiring Diagram

Internal Baseplate of Backup Control

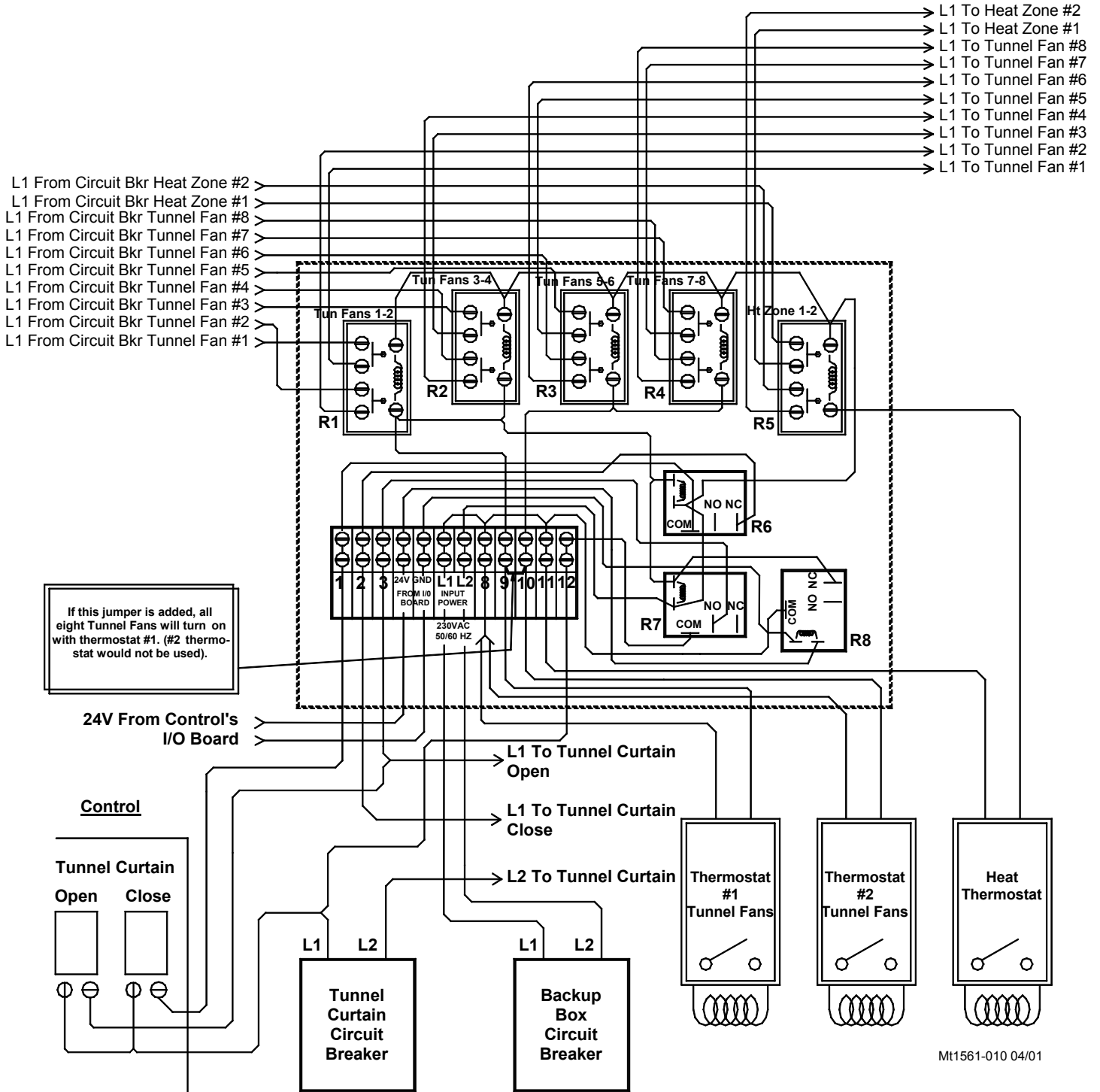

M11561-010 04/01