



Cone for Metal SlantWall Fans Assembly and Installation Manual Part No. 48"(A37935), & 36"(37936)

Thank You

The employees of Agile Manufacturing would like to thank you for your recent purchase. If a problem should arise, your ProTerra™ Fan Dealer can supply the necessary information to help you. The Cone is designed to fit Agile Manufacturing's Metal Slantwall Cone Fans.

Cone Assembly

The Cone must be Installed in the field. The Fan must be installed in the wall before installing the Cone to the Fan.

1. Lay the Cone Panels, with the flanges up, on a flat surface as shown in the Figure below.
2. Loosely fasten the Side Panels together with (3) 5/16-18 x 5/8" Carriage Bolts, (3) 3/8" Lock Washers, and (3) 5/16"-18 Hex Nuts per joint. Only install hardware at the locations shown in the Figure below.
3. Set the Cone Side Panels up and align the ends to create the cone shaped housing. Loosely, secure the ends similar to the other joints.

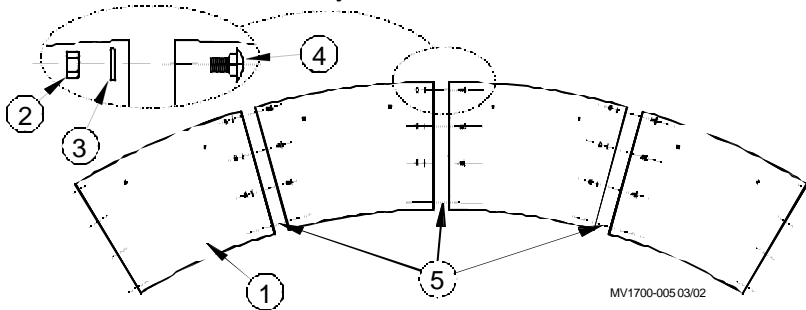

Cone Assembly		
Item	Description	Part No.
1	48" Cone Panel	48040
	36" Cone Panel	37804
2	5/16-18" Hex Nut	2145
3	3/8" Lock Washer	5747
4	5/16-18 x 5/8" Carriage Bolt	8282
5	Do not install Hardware here.	

Grill Installation

1. Position the Grill in the larger end of the Cone Assembly
2. Secure the Grill in place using 5/16-18 Carriage Bolts, 3/8" Lock Washers, and 5/16"-18 Hex Nuts.
(See Figure below)

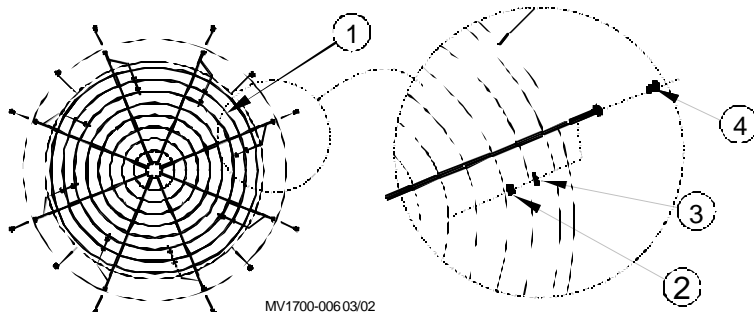

Grill Installation		
Item	Description	Part Numbers
1	48" Fan Grill	37630
	36" Fan Grill	37629
2	5/16-18" Hex Nut	2145
3	3/8" Lock Washer	5747
4	5/16-18 x 5/8" Carriage Bolt	8282

Cone Installation

1. Secure the Cone Hanger Brackets to the Fan Shroud, using 5/16"-18 Carriage Bolts, 3/8" Lock Washers, and 5/16"-18 Hex Nuts **(See Figure below)**.
2. Lift the Cone Assembly to the Fan Shroud. Slide the smaller end of the Cone Assembly over the Fan Shroud.
3. Rotate the Cone Assembly to align the Cone Flanges with the Cone Hanger Brackets. Secure the Cone Assembly to the Cone Hanger Brackets using (4) 5/16"-18 Carriage Bolts, 3/8" Lock Washers, and 5/16"-18 Hex Nuts **(See Figure below)** Tighten all the hardware after the Cone Assembly is secure in place.

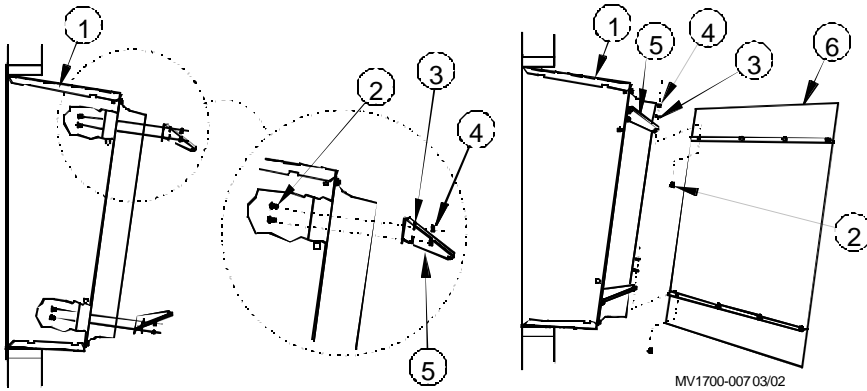

Hanger Bracket Installation		
Item	Description	Part No.
1	Fan Assembly	
2	5/16-18 x 5/8" Carriage Bolt	8282
3	3/8" Lock Washer	5747
4	5/16-18" Hex Nut	2145
5	Cone Hanger Bracket	37806
6	48" Fan Cone Panel	48040
	36" Fan Cone Panel	37804

Warranty Information

See Fan Manual for Warranty information.



Agile Manufacturing
 720 Industrial Park Rd.
 Anderson, Missouri 64831 U.S.A.
 Phone: 1-800-704-7356 • Web Site: www.proterrasystems.com • E-Mail: agile@agilemfg.net
 Agile Manufacturing is a division of CTB Inc. Milford, Indiana

Printed in the U.S.A